

POWER STEERING
PUMP MOUNT
405L
LT-1
Camaro - Firebird

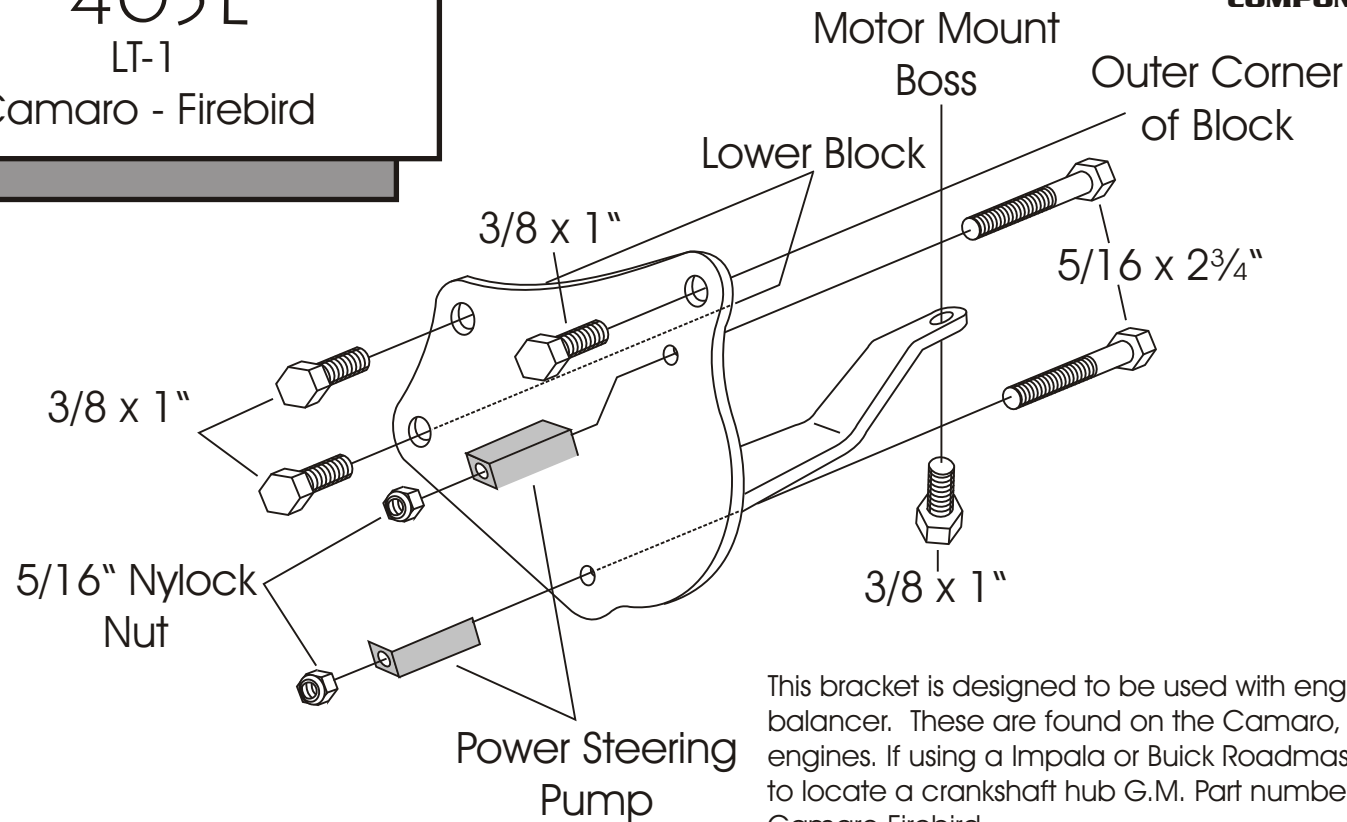

This bracket is designed to be used with engines using the 1 5/16" balancer. These are found on the Camaro, Firebird and Impala engines. If using a Impala or Buick Roadmaster engine, you will need to locate a crankshaft hub G.M. Part number 1255325 for a 1993-95 Camaro Firebird.

This bracket is designed for the G.M. remote reservoir Type 2 pump. These pumps are available from a number of sources. G.M. Part No. 26048280, Durex Part No. 6319, ATSCO Part No. 6319. We also recommend Mullins Steering Gears at (860) 482-8283 for these pumps in aluminum. Mullins Part No. 6319A Plain, 6319P Polished. This bracket requires the use of power steering pump pulley No. 619 from March Performance at (734) 729-9070.

Note: If your pump has threaded mounting holes it will be necessary to drill them to 5/16."

As with any part of this nature, make sure it fits your application before painting or plating. Parts that have been painted, plated, or modified may not be returned.

POWER STEERING
PUMP MOUNT
405L

LT-1
Camaro - Firebird

ALAN GROVE COMPONENTS, INC.
27070 METCALF ROAD
LOUISBURG, KS 66053