

# ALTERNATOR MOUNT 234L

Small Block Chevy - Long Water Pump  
Driver's Side

We use a belt length of 56 - 57 " with this mount on installations in our shop. However; this can vary with the diameter of your pulleys.

As with any mount system, assemble all of the brackets to engine BEFORE TIGHTENING THE BOLTS.

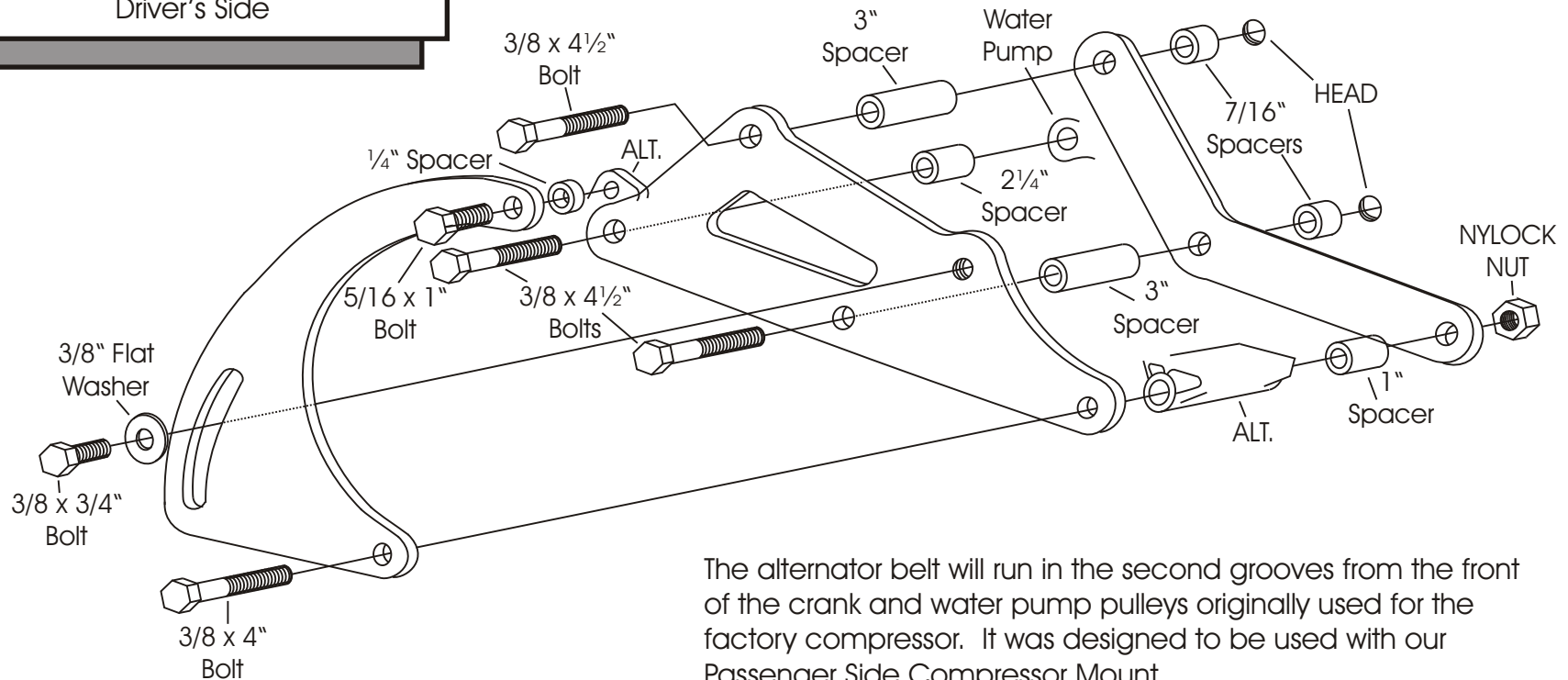

The alternator belt will run in the second grooves from the front of the crank and water pump pulleys originally used for the factory compressor. It was designed to be used with our Passenger Side Compressor Mount.

It can be used with single groove crank and water pump pulleys by using a double groove alternator pulley and running the belt in the outer groove.

**As with any part of this nature, make sure it fits your application before painting or plating. Parts that have been painted, plated, or modified may not be returned.**

ALTERNATOR  
MOUNT

234L

Small Block Chevy - Long Water Pump  
Driver's Side

**ALAN GROVE COMPONENTS, INC.**  
**27070 METCALF ROAD**  
**LOUISBURG, KS 66053**