

LOWER ALTERNATOR MOUNT 227R

1992 - 96 LT-1 Corvette Engine
Passenger's Side



BELT INFO:

Requires the use of a 31 1/2" belt.
Dayco Part No. 5050315.

This bracket requires the use of a 2-1/8" thick 1992-96 **Corvette balancer only**. If using a Caprice, Impala or Buick LT engine: a crankshaft hub used on 1992-96 Corvette and Camaro-Firebird applications will be required for correct pulley alignment. The bracket is designed to be used with the small CS 130 G.M. Alternators with the threaded mounting ear in the 10 o' clock position used on all 1987-93 Chevrolet 2.8 liter V-6 engines (S-10 Pickups).

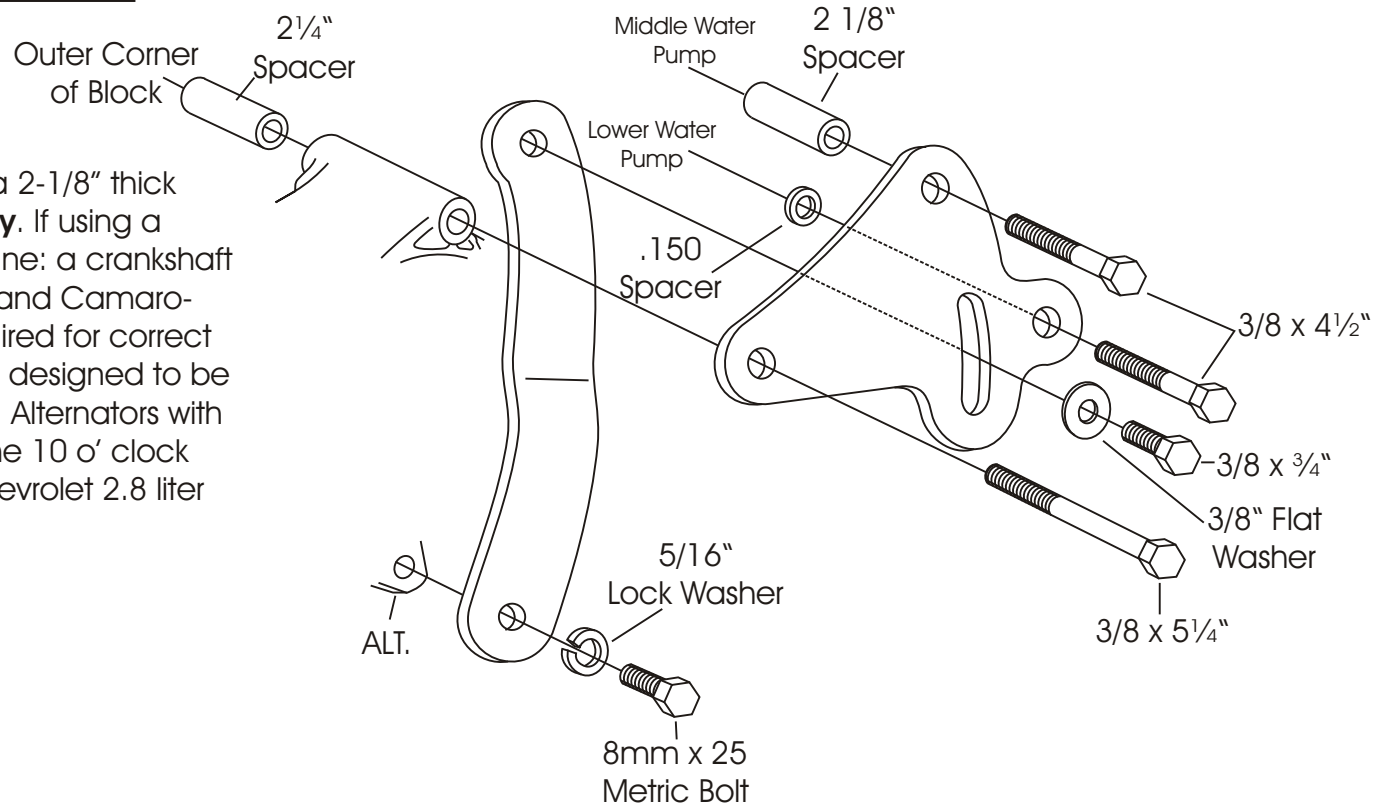

**CS 130 Alternator
Front View**



As with any part of this nature, make sure it fits your application before painting or plating. Parts that have been painted, plated, or modified may not be returned.

LOWER
ALTERNATOR
MOUNT
227R

1992-96 LT-1 Corvette Engine
Passenger's Side

ALAN GROVE COMPONENTS, INC.
27070 METCALF ROAD
LOUISBURG, KS 66053